



INSTALLATION GUIDE



FOR USE IN MULTI-CHANNEL MUSIC OR HOME THEATER SYSTEMS
HIGH DEFINITION, LEFT/CENTER/RIGHT CHANNEL, IN-WALL LOUDSPEAKER

HDLCR

CONGRATULATIONS!

Thank you for choosing the **HDLCR High-Definition, Left/Center/Right Channel In-Wall Loudspeaker** from Niles. With proper installation and operation, you should enjoy years of trouble-free use.

Niles manufactures the industry's most complete line of custom installation components and accessories for audio/video systems. To see the complete Niles product assortment, visit us on the Internet at: www.nilesaudio.com

TABLE OF CONTENTS

Introduction	1
Features and Benefits	1
Installation Considerations	3
Speaker Placement	6
Installation Fundamentals	9
New Construction: Installing A Bracket	14
Existing Construction: Installing A Bracket	16
Finishing the Installation	17
Operation	22
Removing the Grille and Speaker	22
Specifications	23
Limited Warranty	24
Warranty Registration Card	25



INTRODUCTION

The Niles HDLCR High-Definition, Left/Center/Right Channel, In-Wall Loudspeaker is expressly designed for superior sonic quality in front-, center-, or rear-channel applications. It employs advanced technology components that extract the subtle nuances in recorded music or the thunderous action sound in a movie. The HDLCR is the perfect choice wherever quality of sound is the most important consideration.

FEATURES AND BENEFITS

INJECTION-MOLDED TCC WOOFERS WITH BUTYL-RUBBER SURROUND, LONG-THROW VOICE COIL/MAGNET STRUCTURE, AND VENTED POLE PIECE

The HDLCR features newly-developed woofer-cone material that combines injection-molded polypropylene with talc, carbon, and ceramic (TCC) stiffening agents. As a result, the cone offers extreme stiffness and light weight for accurate, dynamic response. A long-throw voice coil/magnet structure ensures increased cone excursion to enhance low frequency response and dynamic impact. Additionally, each woofer employs a vented pole piece for increased bass linearity and a butyl-rubber surround for improved midrange damping and clarity as well as moisture resistance.

1-INCH TETERON TRI-LAMINATE TWEETER HOUSED IN A PRECISION ADJUSTMENT MECHANISM

The HDLCR's Teteron Tweeter employs a tri-laminate design consisting of an inner textile layer, which forms the dome, a high damping layer to kill unwanted resonances, and an outside layer of urethane to add stiffness and prevent breakup modes. The result is a transparently clear, sweet, natural-sounding tweeter, which still maintains extended frequency response. This advanced tweeter is housed in a precision adjustment mechanism, which permits the tweeter to be accurately positioned after installation for optimum performance and without the diffraction distortion typical of traditional pivoting tweeters.

DIRECTED SOUND FIELD GEOMETRY™ (DSFG) DELIVERS OPTIMUM PHASE RESPONSE TO LISTENERS AND COMPENSATES FOR HIGH SPEAKER PLACEMENT

The HDLCR employs Niles' Directed Sound Field Geometry (DSFG). With DSFG, the tweeter is offset from the center of the dual woofers. The resulting acoustic interaction between the woofers and the offset tweeter results in the flattest frequency and phase response, approximately 15-degrees off-axis from the tweeter. This gives optimum performance to a seated listener, even if the loudspeaker is mounted above a built-in TV.

INSTALLER-SELECTABLE ACOUSTIC FINE TUNING

Using the baffle-mounted TREBLE and BASS CUT controls, the installer can de-emphasize the bass and/or treble response by 3 dB after installing the HDLCR to precisely tone match the sound in any room.

CTR L/R MODE SWITCH

The HDLCR includes a baffle-mounted CTR L/R mode switch to optimize performance in applications as either a center channel or left/right loudspeaker for front-channel use.

EASY RETROFIT INSTALLATION IN YOUR EXISTING HOME

Designed for ease of installation, the Niles mounting system makes retrofit installations simple and fast. A supplied template assures fast and accurate hole cutting. The bracket slips behind the drywall and the screws secure the bracket to the frame, sandwiching the drywall between them. The speaker baffle attaches to the frame, and the grille mounts over the speaker.

THREE-STAGE INSTALLATION SYSTEM FOR REMODELS OR NEW CONSTRUCTION

Only the parts needed are installed during a particular stage of construction. After framing and wiring are finished, the bracket is installed. After the drywall is up, but before the painter begins to paint, the frame is installed, and the rustproof aluminum grille is left for the painter to match to the surroundings. The speaker is installed only when construction is completely finished. Masking or prepping the speaker for painting and worries about speaker theft during final construction are never an issue!

MICROPERF™ ALUMINUM GRILLES

Niles' exclusive MicroPerf™ grille construction provides an exceptionally tight hole pattern for acoustic transparency at all audio frequencies and enables the speaker elements to remain invisible. MicroPerf aluminum grilles can also be painted to blend seamlessly with the surrounding decor. Additionally, the aluminum grille material will never rust or discolor over time.

INFRARED SENSOR MOUNT

The speaker baffle has a locator designed for the Niles MS-100 MicroSensor®, a miniature infrared sensor. The MS-100 installs discreetly behind the aluminum grille to minimize wall clutter in the home. To control the equipment, the listener simply points the remote control at the speaker from up to 15 feet away.



NILES' HD HIGH-DEFINITION VOICE MATCHING

Ensures compatibility with other Niles HD High-Definition in-wall, on-wall, and ceiling-mount models to accommodate a wide range of system designs.

DOLBY® DIGITAL READY

The HDLCR is specifically designed for Home Theater Sound. This model exceeds the specifications set forth by Dolby Laboratories for the accurate reproduction of Dolby Digital-Encoded Sources.

INSTALLATION CONSIDERATIONS

Figure 1. Mounting an HDLCR loudspeaker into a wall.

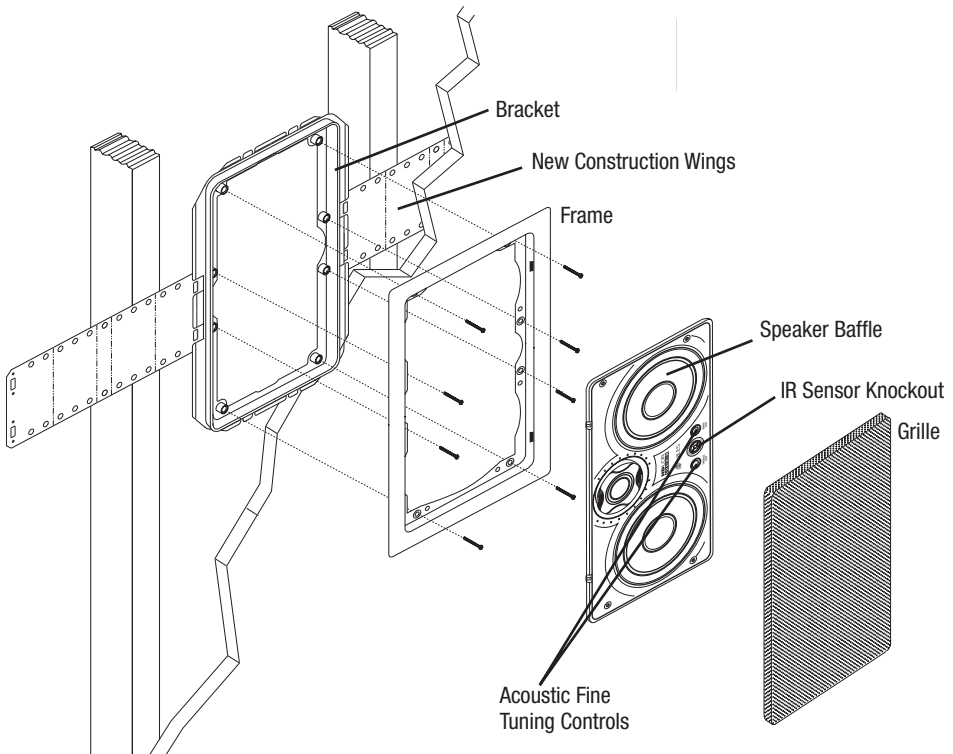

TOOLS AND PRECAUTIONS

We recommend using the following tools to install a HDLCR loudspeaker:

- *Electric drill with 1/4- and 1/2-inch drill bits, and a 1-inch flat drill bit (for drilling through studs)*
- *Keyhole or drywall saw*
- *Stiff wire, fish tape, or glow rods (for routing cables)*
- *Phillips screwdriver set*
- *Cable ties*
- *Pencil*
- *Level*
- *Rubber gloves and protective eyewear*

Before starting the installation, please observe the following precautions:

- *Turn off all system power before making any connections.*
- *Always wear protective eyewear when using tools.*
- *Make sure hands are clean before installation.*
- *Wear gloves when working with fiberglass insulation.*

RECOMMENDED AMPLIFIER POWER

For satisfactory performance, we recommend using a surround amplifier with a power rating of 10 to 125 watts. Curiously, most loudspeakers are not damaged by large amplifiers, but rather by small amplifiers. If your system is playing loud music, a small amplifier will run out of power very quickly and can create damaging “clipping” distortions. A more powerful amplifier will play at the same volume without distorting. See **OPERATION** on page 22 for more information about amplifier clipping distortion.



LOUDSPEAKER WIRE

Use 2-conductor loudspeaker wire when connecting loudspeakers to your receiver or amplifier. For most applications, we recommend using 16- or 18-gauge wire. For wiring runs longer than 80 feet, we recommend 14-gauge wire. The spring-loaded terminals of the HDLCR will accommodate up to 12-gauge wire directly. Larger sizes can be accommodated via pin connectors.

When running wire inside walls or ceilings, use special jacketed cable (CL-2 or CL-3) to protect the wire and for fire prevention. In some areas, conduit is also required. For a trouble-free installation, low-voltage wire such as speaker wire must be run in accordance with the National Electrical Code and any applicable provisions of the local building code. If you are unsure of the correct installation techniques, wire jacket, or type of conduit to use, consult a professional audio/video installer, building contractor, or the local building and inspection department.

INCORPORATING A REMOTE CONTROL

If you are planning to use a stereo system with a hand-held IR remote control, consider the advantages of having a Niles IR Repeater system installed. It will allow you to control all of the functions of your system from the room with the remote pair of speakers.

Niles makes a number of IR sensors, which install in the wall, in the ceiling, in cabinetry, on tabletops, or even behind the grille of your Niles HDLCR speaker. An IR sensor requires that a CAT5 cable be home run from each sensor location to the main equipment location. This wire is normally run beside the speaker wire at the same time. Typically, the sensor is placed in a location that faces the listening position.

Most remote controls will have an effective line-of-sight range of 18 to 30 feet when used with any Niles sensor placed in a wall, ceiling, on a cabinet or tabletop. However, when a Niles MS-100 MicroSensor® is used behind the HDLCR's perforated aluminum grille, the effective range is reduced to 9 to 15 feet.

INSULATING THE WALL CAVITY

For best performance from your speakers, fill the wall cavity behind the speaker with fiberglass insulation (e.g., R-19 un-batted insulation). Try to keep the same amount of insulation for each speaker, particularly in the same room, for consistent bass response.

TECH TIP

Wire size is expressed by its AWG (American Wire Gauge) number – the lower the number, the larger the wire. For example, 12 AWG is physically larger than 14 AWG.

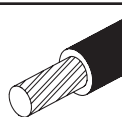

SPEAKER PLACEMENT

NOTE: THE NILES HDLCR LOUDSPEAKER IS DESIGNED FOR USE IN FRONT LEFT-, CENTER-, OR FRONT RIGHT-CHANNEL APPLICATIONS ONLY. FOR REAR-CHANNEL APPLICATIONS, WE RECOMMEND USING A NILES HDFX OR CM6HDFX LOUDSPEAKER.

PLACING THE HDLCR AS THE FRONT LEFT AND RIGHT SPEAKERS

In a home theater, the intelligibility of dialog and action reproduced by the front speakers is paramount! The position of the speakers plays a very important role in how clear the sound is and how a stereo image is created. Here are some guidelines to make the process of placement quick and easy:

- *Make sure the sound will not be blocked or reflected off furniture or other objects. The listener should have a direct line of sight with the front of the speaker. To determine the best position, measure the “listening” distance between the ideal listening position (e.g., favorite chair or couch) and the wall in which you plan to install the speakers.*
- *For stereo music applications, try to place the speakers so that they are equally distant from the listening spot and at least one half of the listening distance apart to maintain a large pleasant stereo “image.”*
- *In home theater applications where there is a center channel, you may choose to space the left and right main speakers farther apart for a “bigger than life” sound with Dolby® encoded movies and TV shows. However, for combined music and movie usage, we recommend using the placement zone for stereo music. Ideally, if the listening position is 10 feet back from the wall, place the speakers between 5 and 10 feet apart, as shown in **Figure 2**.*

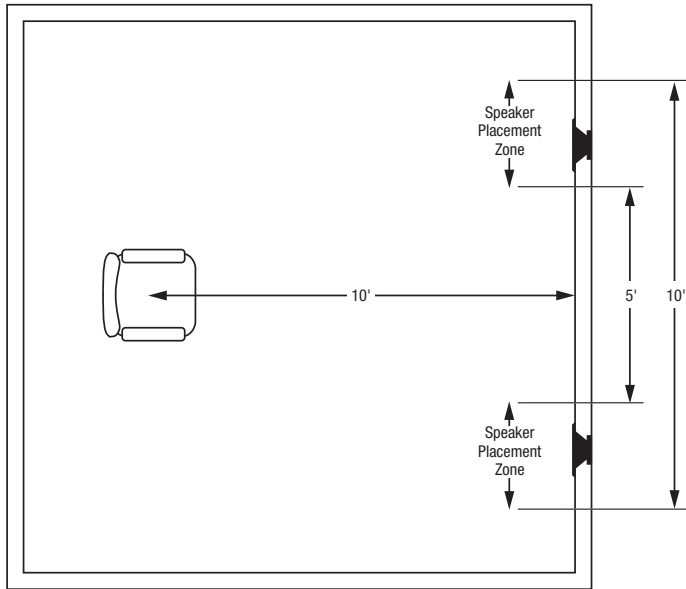

Figure 2. Recommended HDLCR loudspeaker placement for front left and right channels.

As for placement height, place front left and right speakers on either side of the picture source so that their tweeters are not more than 24 inches above or below the center-channel speaker's tweeter (see **Figure 3** on page 8).

NOTE: DO NOT PLACE AN HDLCR SPEAKER TOO CLOSE TO A DIRECT-VIEW TV MONITOR, AS IT MAY CAUSE PICTURE DISCOLORATION. IN GENERAL, TRY TO KEEP IT AT LEAST 24 INCHES AWAY FROM THE TV. WITH LARGER CRT SCREEN SIZES, TEST THE PLACEMENT DISTANCE FOR PICTURE DEGRADATION BEFORE INSTALLATION.

THE BOUNDARY EFFECT

Placing a speaker in a corner can powerfully affect the way a listener perceives bass response. Known as the boundary effect, placing speakers close to a wall/ceiling boundary or near a corner-wall boundary will emphasize certain bass frequencies, while canceling others. This effect can make the speaker sound excessively boomy and inaccurate to some listeners, while to others it just seems like more bass sound.

As a good rule-of-thumb, if you like listening to your current pair of speakers with the bass turned up, you'll enjoy corner placement. However, if you listen with the tone controls at neutral, try keeping the speakers at least 2 or 3 feet from the boundaries of the room.

PLACING AN HDLCR AS THE CENTER-CHANNEL SPEAKER

The center-channel speaker is the workhorse in a home theater system. It handles all of the critical dialog and is vitally important in creating the illusion of sounds emanating directly from the picture. Here are some tips for obtaining optimum center-channel performance:

- *In a typical installation, place the HDLCR horizontally, directly above the television or projection screen. Try to insure that the speaker is not placed too high relative to the left and right speaker, as shown in **Figure 3**.*

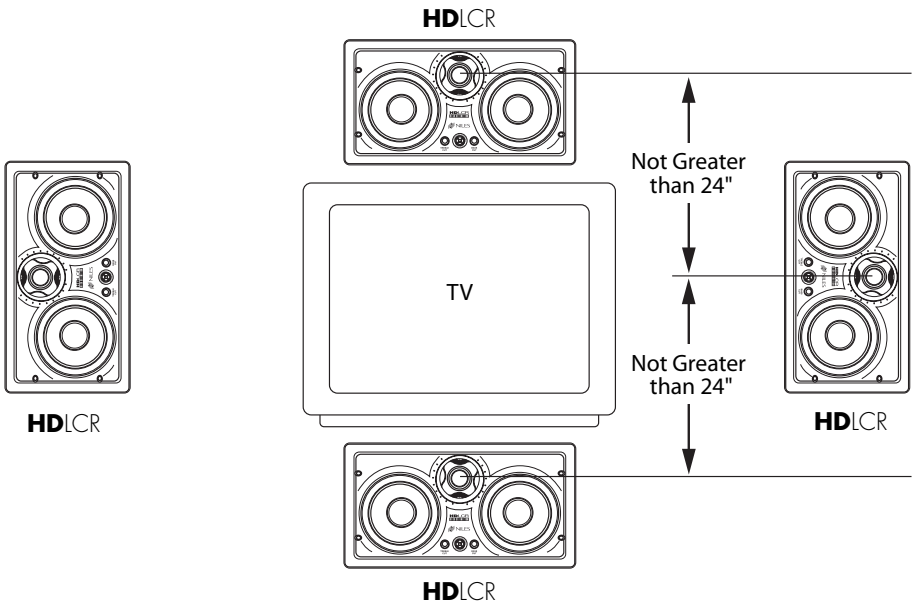

Figure 3. If the HDLCR is placed above a TV, install the speaker with the tweeter up. If it is placed below a TV, install the HDLCR with the tweeter down.

- For installations where a perforated projection screen will be used, place the HDLCR, either horizontally or vertically, behind the screen at ear level, as shown in **Figure 4**.

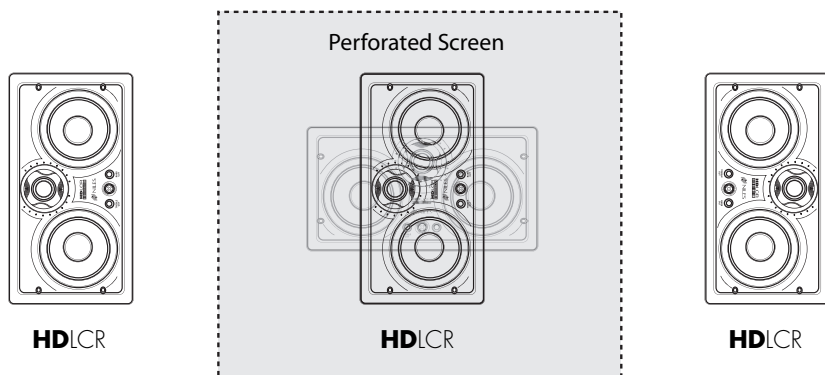

Figure 4. Recommended HDLCR center-channel placement behind a perforated projection screen.

INSTALLATION FUNDAMENTALS

RUNNING THE SPEAKER WIRE IN NEW CONSTRUCTION

IMPORTANT: IF YOU HAVE DOUBTS ABOUT WHETHER YOU ARE CAPABLE OF INSTALLING A NILES CEILING-MOUNT LOUDSPEAKER, PLEASE CONSULT A NILES DEALER OR PROFESSIONAL INSTALLER. THEY HAVE SPECIAL TOOLS, TECHNIQUES, AND EXPERIENCE TO MAKE THE IMPOSSIBLE JOB POSSIBLE. THE INSTALLER CAN PROVIDE YOU WITH AN ESTIMATE BEFORE ANY WORK IS DONE.

OBSERVE SAFETY FIRST!

- *Always wear gloves, safety goggles, and head protection gear when drilling or cutting holes.*
- *Avoid drilling near nails – they ruin bits and can cause injury.*
- *Be careful using “hole-hogs” and other powerful electric drills. The torque of this drill when suddenly stopped by a nail can break the wrist of a strong man.*

RUNNING THE SPEAKER WIRE IN NEW CONSTRUCTION (CONTINUED)

SCHEDULING AND PREPARATION

Plan to schedule the speaker wiring after the electrical wiring is finished. That way you can avoid wire routes, which could potentially induce hum over the speaker wire. The basic wiring rules are:

- *Never run speaker wire through the same hole as an electrical cable.*
- *Never run speaker wire into the same J-box as electrical cable.*
- *Avoid running the speaker wire beside the electrical cable. Keep your speaker cable at a distance of at least 18 to 22 inches from any electrical power cable.*
- *If side-by-side wiring is unavoidable in particular spots in the house, move the speaker wire route away as soon as possible.*
- *If construction forces a side-by-side run for more than 10 feet, install metal conduit or shielded speaker wire. Low-voltage wires such as doorbells, intercoms, telephone, security, or television cannot cause interference or hum on your speaker wires, so you can safely run all of them at the same time, through the same holes, side-by-side.*
- *Before drilling any holes, mount the speaker brackets in the desired speaker Locations and mount p-rings or open-backed J-boxes where the in-wall volume Controls and stereo equipment will be located.*

ABOUT DRILLING

Use a bit that is large enough for the wires you plan to run. This is an important consideration, since you may be drilling a lot of holes. Here are some additional tips:

- *We recommend using an auger bit for rough-in wiring. It will actually pull itself through the wood, so that the drill motor, not you, does most of the work.*
- *Always drill the holes in the center of the stud. If you have to notch the stud or drill the hole closer than 1 inch from the edge of the stud, protect the wire with a nail plate, as shown in **Figure 5**.*

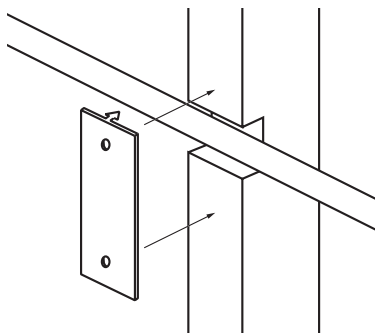

Figure 5. Installing a nail plate to protect wiring in a notched stud.

- *When drilling holes in ceiling joists, drill in the center of the joists and try to locate the hole near the end of the joist.*

IMPORTANT: DO NOT DRILL THROUGH A GLU-LAM OR LOAD-BEARING BEAM WITHOUT THE DIRECTION OF YOUR CONTRACTOR.

- *Try to line the holes up perfectly, because it makes pulling the wire much easier. A good technique is to snap a chalk line across the face of the studs or against the bottom of the ceiling joists. Then work backward so that you can always see the holes you have already drilled. Paying careful attention to this will save you time later on.*

PULLING THE CABLE

Pull the cable in sections (from the stereo to the volume control, from the volume control to the speaker). Start with the longest sections and use leftover wire to complete the short sections. Also consider the following wiring tips:

- *If you plan to pull many rooms at the same time through a central route, walk off the Distance to each destination, add a generous “fudge factor” for turns and other Obstacles, and then cut off each section, so you can pull a bundle of wires at once.*
- *When running the wire further than 4-1/2 feet from a hole in a stud or joist (e.g., open attic space, going up walls, etc.), be sure to fasten the wire to the joists or studs using cable clamps or appropriately-sized wire staples. The wire should not have large sags in it, nor should it be too tight.*
- *Try to protect the wire from being stepped on in attics or other unfinished crawl spaces. Use guard strips, raceways, or conduits to protect the cable. Consult the local building code for special requirements in your area.*

CONCEALING SPEAKER WIRE

ABOUT INTERIOR WALLS

Interior walls in almost all North American residences are hollow, so they are easy installation sites for flush mounting speakers and routing new speaker cable in the house. Looking at a painted wallboard, plaster, or paneling, you only see the skin of the wall. Behind it is the home’s skeleton; 2-by-4 inch wood or metal “studs” running vertically from the floor to the ceiling in walls and 2-by-6 inch or larger “joists” running horizontally in the ceilings and floors. The space between the studs and joists is used for the home’s wiring and plumbing.

(CONTINUED ON NEXT PAGE)

CONCEALING SPEAKER WIRE (CONTINUED)

ABOUT EXTERIOR WALLS

Concealing wires in exterior walls is more complex, since the walls are stuffed with insulation to protect the house from the heat and cold outside. Moreover, our national building code requires that a horizontal stud placed between the vertical studs break the hollow wall space in exterior walls. This “fire blocking” makes it very difficult to retrofit long lengths of wire. In some areas of the country, the exterior walls are constructed of solid masonry and have no hollow space for speakers or wires.

PLANNING THE SPEAKER WIRE ROUTE

Start by examining all the possible routes you might take to run the speaker wire from the speaker to the home theater system. Use a stud sensor or other device to locate the internal structure of the wall. You will want to avoid all studs or joists. **Figure 6** shows a typical wire run from the speaker location in the ceiling, across the attic, then down through a top plate (i.e., the horizontal 2-by-4 or 2-by-6 inch wood laid across the vertical studs) to a wall plate or a J-Box in the wall behind the home theater system itself.

Figure 6. Running speaker wire from a ceiling speaker to a home theater system location.

Find all the locations of your existing electrical, phone, and TV wiring, and then plan the speaker wire route to avoid them. Crossing wire paths is acceptable, but 60 Hz hum may be induced in the reproduced audio, if speaker wire is run parallel to electrical wire for more than a few feet. If possible, try to keep speaker wire away from parallel power cables by at least 3 feet.

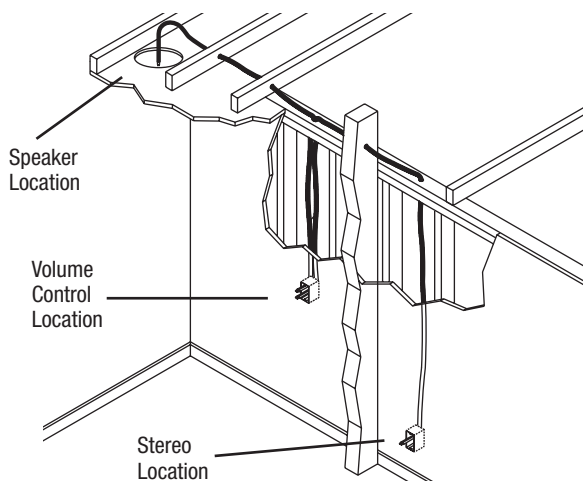

To find exactly where an electrical cable is routed, try inspecting the inside of the wall by turning off the breaker for a particular power outlet or switch, removing the cover plate and switch or receptacle, and then shining a penlight into the wall. If you have access to an attic or basement space, you can quickly see which part of the wall space is free of obstructions, as shown in **Figure 7**.

Figure 7. An example of unobstructed wall space for speaker wiring.

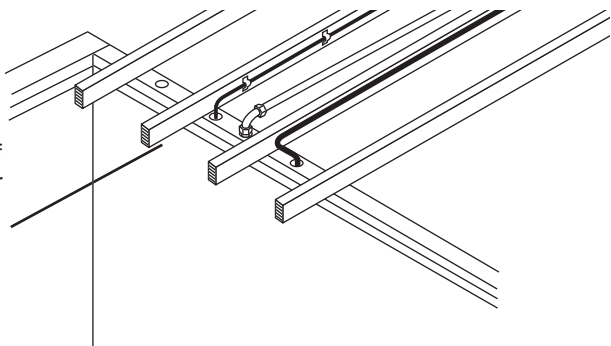

When you don't have access above or below the wall, try to estimate the existing wire and pipe locations from known positions of electrical outlets and plumbed fixtures on both sides of the wall. Take a look at the outside of your house too – sometimes conduit, vents, or drainpipe will provide useful visible clues. Choose the route with the fewest potential obstacles.

If the home is built on a slab, or a speaker wire route is planned between two finished floors, look for baseboards that could be removed for wire placement. Doorjamb can also be removed and often have enough space for speaker wire all the way around the door, as shown in **Figure 8**.

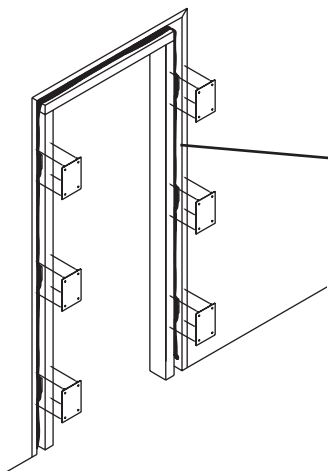

Figure 8. Running speaker wire between a wall and a removed doorjamb. Nail plates are also installed to protect the wire when the doorjamb is replaced.

OTHER POSSIBLE SPEAKER WIRE ROUTES INCLUDE:

- *Under-the-carpet runs using flat speaker wires.*
- *Heating and air conditioning vents used as wire raceways for plenum-rated wire.*

NOTE: CHECK YOUR LOCAL BUILDING CODES, SINCE SOME MUNICIPALITIES REQUIRE CONDUIT.

(CONTINUED ON NEXT PAGE)

CONCEALING SPEAKER WIRE (CONTINUED)

CUTTING HOLES

In traditional wood stud/drywall construction, first cut the hole for the speaker. Then, in the opening, use a drill with a long bit to auger a wire route up or down the wall. Next, cut a hole in the drywall for stud access, drill holes through the studs, and run your wire, as shown in **Figure 9**.

After the wire has been run, patch the hole with the cut drywall using standard drywall joint tape and joint compound. Let the patch dry, sand the surface, and touch-up the wall with paint.

NOTE: BE PATIENT WITH UNKNOWN STRUCTURES OR DIFFICULT-TO-PATCH WALL MATERIALS LIKE PLASTER, LATH AND PLASTER, FAUX FINISHES, WALLPAPER ETC. ALWAYS PERFORM A CAREFUL STUDY OF THE POTENTIAL PROBLEMS BEFORE STARTING THE JOB.

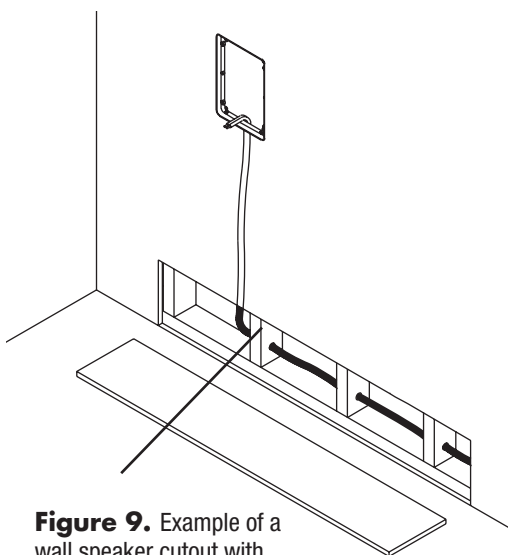

Figure 9. Example of a wall speaker cutout with studs drilled for wire run.

NEW CONSTRUCTION: INSTALLING A BRACKET

The hole-saving bracket enables a faster and cleaner final installation of the speaker. It forces the drywall installer to cut out the speaker hole for you and provides wire ties for the speaker wire, reducing the risks of accidental loss or movement of the wire. In addition, it enables you to align your speakers with other ceiling fixtures with greater accuracy, since you can see exactly where the speaker will be.

INSTALLING THE BRACKET

1. *Attach the QuickSnap™ new-construction wings to the bracket by snapping them into the bracket sides. If the length will interfere with corner or eaves, shorten the wings by breaking them along the scored lines. You can mount the bracket horizontally or vertically, as shown in **Figure 10**.*

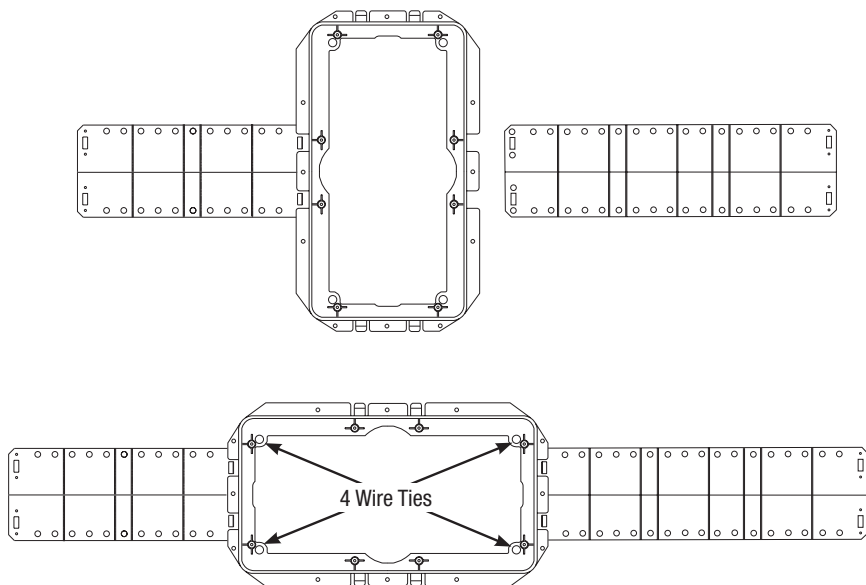

Figure 10. The hole-saving brackets with QuickSnap new-construction wings can be installed horizontally or vertically.

2. *Screw one side of the assembled bracket with wings to the stud or joist, using one of the supplied screws. Level the bracket, and then screw the other side of the bracket/wing assembly to the stud or joist. Two screws on each side make for a very secure installation.*
3. *Attach the wire to the bracket at the indicated wire tie points, as shown in Figure 10.*

CONCEALING SPEAKER WIRE FOR A FUTURE INSTALLATION

1. *Attach the speaker wire in a loop between the ceiling joists and carefully mark the exact location of the wire on a set of plans.*
2. *Ask the general contractor to inform the drywall installers that the speaker wire loops are concealed for future installations, as shown in Figure 11.*

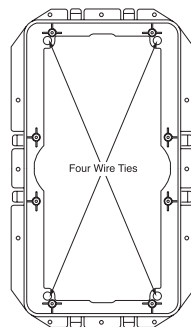

Figure 11. The speaker wire is looped and hung on two nails attached to the joists, securing it for future use. Be sure to note the location on house plans.

EXISTING CONSTRUCTION: INSTALLING A BRACKET

IMPORTANT: BEFORE YOU CUT INTO ANY WALL, REVIEW THE SECTIONS ON SPEAKER PLACEMENT ON PAGE 6 AND RUNNING THE SPEAKER WIRE IN NEW CONSTRUCTION ON PAGE 9. BE SURE NOT TO DRILL OR CUT THROUGH EXISTING WIRES, PIPES, OR STRUCTURE. IF YOU FEEL ANY EXTRA RESISTANCE AS YOU ARE DRILLING OR SAWING, STOP!

1. *Locate studs or joists by using a stud sensor or by hand knocking. Do not place the edge of the cutout directly next to a stud or joist, since the frame and bracket will extend beyond the cutout.*
2. *At the planned cutout site, drill a 1/8-inch pilot hole just barely through the wall, about an inch below the center of your proposed speaker location.*

NOTE: IN MOST HOMES, THE WALL THICKNESS IS 1/2 TO 5/8 INCH.

3. *Cut a foot-long piece of coat hanger and bend it to create a right angle. Poke the “L-shaped” wire into the pilot hole and turn it in a complete circle, as shown in **Figure 12**.*
4. *Continue turning the coat hanger as you move it into the cavity to a depth of approximately 4 inches. If you feel an obstruction, fill the hole(s) with spackling compound and repeat steps 1 through 4 at a new location.*
5. *If the coat hanger moves freely in a complete circle, hold the supplied template up to the wall or ceiling and level it in the horizontal or vertical position. Use a pencil to outline the cutout on the surface and then drill the four corner holes with a 1/4-inch bit (see **Figure 13** on page 17).*

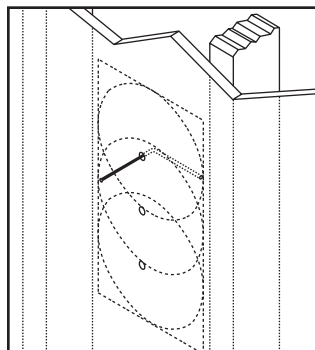

Figure 12. Using a coat hanger to check for obstructions behind the wall speaker site.

6. *If you are cutting drywall, use a sheetrock or keyhole saw. Cut the outline with the saw at a 45-degree angle. That way, the drywall section can be replaced cleanly if there is an unseen obstruction behind the wall.*
7. *If you are cutting into a plaster ceiling, use masking tape to outline the penciled opening and use a razor to score the plaster down to the lath beneath. Then use a chisel to remove all of the plaster within the taped outline. To actually cut the lath, consider the following two professional methods:*
 - *Use a saber saw with a metal cutting blade for the quickest cut. However, sawing lath with a saber saw can easily vibrate plaster off the ceiling in a completely distant location, thereby creating more patchwork.*
 - *If you have the patience, use a pair of tin snips to slowly nip away at the lath instead. There is little risk with this method – it is just more time consuming.*

FINISHING THE INSTALLATION

PAINTING THE GRILLE AND FRAME

After drywall is up, each HDLCR frame and grille may be painted without the need for primer. For best results, use a spray gun or airless sprayer, thin the paint to prevent clogging of the grille holes, and apply several light coats instead of one heavy one.

1. *Paint each grille and let it dry before installation.*
2. *Paint each frame and let it dry before installation.*

INSTALLING THE FRAME

1. *Fill each wall cavity with insulation. Remember to use equal amounts of insulation for each speaker.*
2. *For existing construction, slip the mounting bracket through the hole and pull it toward you so that its front edge slides into the hole and stops in place.*

NOTE: FOR NEW CONSTRUCTION, THE MOUNTING BRACKET SHOULD ALREADY BE IN PLACE (AS DESCRIBED IN THE SECTION "NEW CONSTRUCTION: INSTALLING A BRACKET" ON PAGE 14.

3. *Attach each frame to its bracket using the supplied screws, as shown in **Figure 13**. The screws should pull the frame and bracket together (sandwiching the drywall) so that the frame is absolutely flush with the wall surface. There should be no gaps between the wall and the frame.*

IMPORTANT: DO NOT OVER TIGHTEN THE SCREWS! OVER TIGHTENING THEM MAY MAKE THE GRILLE DIFFICULT TO INSTALL.

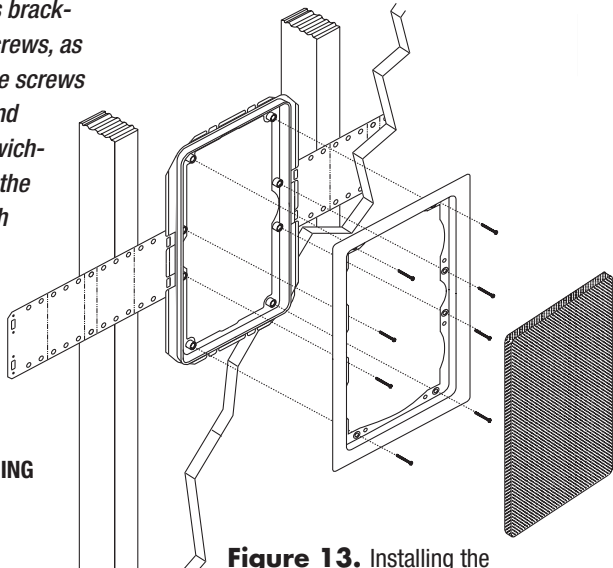

Figure 13. Installing the frame into a mounting bracket.

INSTALLING A NILES MS-100 MICROSENSOR®

1. *For each speaker, locate the half-inch round, molded “IR Sensor Knockout” on the baffle.*
2. *Lay each speaker face down on a clean carpet or rug. Put the tip of a screwdriver into the center of the round “knockout” and sharply tap the screwdriver handle as necessary.*

NOTE: TO PREVENT DAMAGE TO THE CROSSOVER NETWORK, ALWAYS REMOVE A KNOCKOUT FROM THE REAR OF THE SPEAKER. DO NOT ATTEMPT TO REMOVE A KNOCKOUT WITH THE SPEAKER FACE UP.

3. *At each speaker, install the MS-100 (using its mounting hex nut and washer) until it is tightly secured.*
4. *Connect all MS-100 wires.*

SETTING THE CTR L/R MODE

The HDLCR includes a baffle-mounted CTR L/R mode switch to optimize performance in applications as either a center channel or left/right loudspeaker for front-channel use, as shown in **Figure 14**.

- *For front left- or right-channel applications, slide the HDLCR’s mode switch to L/R.*
- *For center-channel use, slide the HDLCR’s mode switch to CTR.*

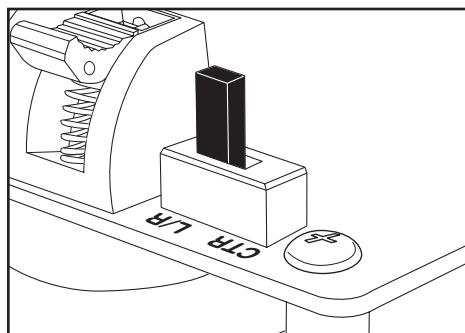

Figure 14. The HDLCR’s CTR L/R mode switch.

CONNECTING AND INSTALLING THE SPEAKER

1. At each speaker, separate the speaker wire so that at least 2 inches of each conductor are free. Strip away 1/4 inch of insulation from each speaker wire.
2. On each set of speaker connectors, press down the spring-loaded lever, insert the appropriate conductor, and then release the lever, as shown in **Figure 15**. Gently tug on the speaker wire to make sure it is held in place. If not, repeat this procedure until it is.

NOTE: OBSERVE CORRECT POLARITY: POSITIVE (+) GOES INTO THE RED TERMINAL AND NEGATIVE (-) GOES INTO THE BLACK TERMINAL.

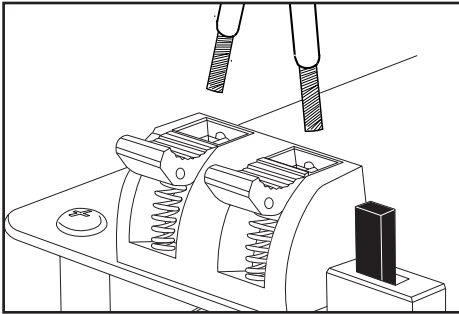

Figure 15. Connecting a speaker wire to the HDLCR terminals.

3. Connect the other end of each speaker wire to the receiver (or amplifier) in the same way. If you are unsure of wire polarity, see the next section, **Checking Speaker Phase** on page 20.

NOTE: OBSERVE CORRECT POLARITY: POSITIVE (+) GOES INTO THE RED TERMINAL AND NEGATIVE (-) GOES INTO THE BLACK TERMINAL.

4. Install the speaker baffle into its frame by inserting the tabs at the base into the corresponding holes in the frame and pushing the speaker forward until the snaps engage, as shown in **Figure 16**.

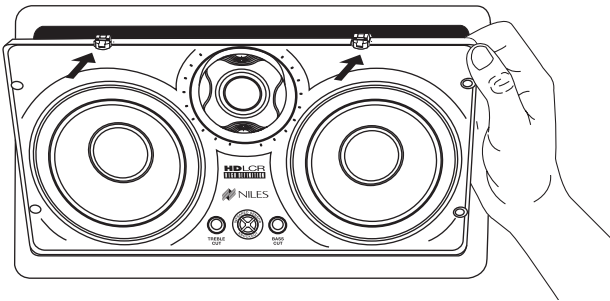

Figure 16. Installing the speaker baffle into its frame.

(CONTINUED ON NEXT PAGE)

CONNECTING AND INSTALLING THE SPEAKER (CONTINUED)

IMPORTANT: WHEN INSTALLING THE SPEAKERS IN THE CEILING, OR IF THE INSTALLATION IS IN AN EARTHQUAKE ZONE, WE RECOMMEND USING THE ENCLOSED SHEET METAL SCREWS TO SECURE THE BAFFLE TO THE FRAME AS FOLLOWS:

- a. *Locate the dimples on the front baffle.*
- b. *Place the self-tapping sheet-metal screw in the dimple and turn it with a screw-driver until it cuts through the baffle and anchors securely in the frame, as shown in **Figure 17**.*

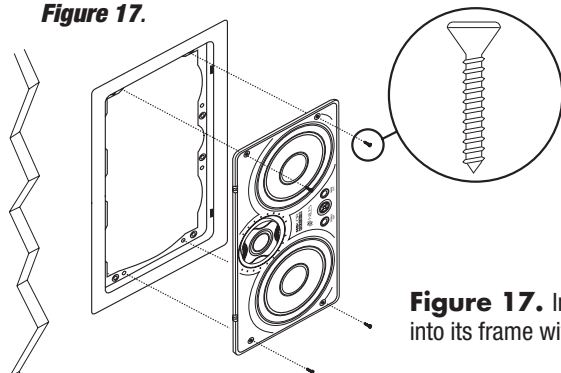

Figure 17. Inserting the speaker baffle into its frame with sheet-metal screws.

5. *Turn on the home theater receiver and calibrate all speakers in the system according to the receiver manufacturer's instructions.*

CHECKING SPEAKER PHASE

Speaker wire has two conductors. On both your speaker and amplifier, one conductor is attached to the negative (–) terminals, while the other is attached to the positive (+) terminals. Usually, the wire is marked for your convenience, but the marking can be done in the following different ways:

- *Stripe on one wire*
- *Ribbed area you can feel on one conductor*
- *Different colors of metal wire on each conductor*
- *Fabric strand or string wound into one of the conductors*

Of course, there are some wires that appear completely identical. So be careful, or you might make a connection mistake. If you do, one speaker will be playing “out-of-phase” with the other speaker. A pair of out-of-phase speakers works against each other, and the sound of the two playing together will be lacking in bass and sound “phasey.” If you suspect the sound is not right, and you cannot see any markings on the wire, try this simple test:

1. Stand halfway between the speakers.
2. Play some music with the amplifier or radio set to Mono.
3. Listen to the richness of the bass and the loudness of the sound.
4. Turn off the amplifier and reverse the connections on one amplifier channel only.
5. Repeat the listening test with the same volume control setting. When the sound has a richer bass and is slightly louder, the speakers are working together or “in-phase.”

ACOUSTIC FINE TUNING

Each HDLCR speaker features separate, baffle-mounted TREBLE CUT and BASS CUT controls for acoustic fine-tuning after installation, as shown in **Figure 18**.

- If a HDLCR is placed near a boundary, set its BASS CUT switch to -3 dB to lower the bass response.
- If a HDLCR is placed in a room with highly reflective surfaces like glass or tile, set its TREBLE CUT switch to -3 dB to lower the high-frequency response.

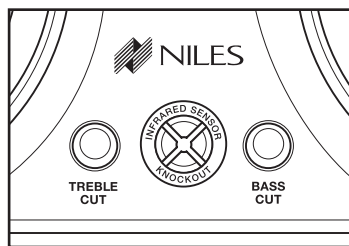

Figure 18. The HDLCR’s TREBLE and BASS CUT switches.

ADJUSTING THE TWEETER

The HDLCR tweeter is housed in a precision adjustment mechanism which enables precise aiming of the directional high frequencies to provide optimum performance. To adjust the tweeter:

1. Carefully grasp the tweeter housing by placing your thumb and forefinger in the indentations provided.
2. Rotate the tweeter housing either clockwise or counter-clockwise as required. The mechanism is indexed at equal intervals so that speakers in a pair can be adjusted equally. Simply count the number of “clicks” as the first tweeter is adjusted. Repeat the process for the second speaker, rotating the tweeter the same number of “clicks” in the opposite direction, as shown in **Figure 19**.

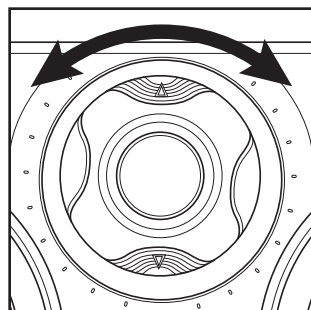

Figure 19. Rotating the HDLCR’s tweeter.

(CONTINUED ON NEXT PAGE)

ADJUSTING THE TWEETER (CONTINUED)

- Pivot the tweeter on each speaker equally by depressing the housing at the arrows until the desired angle is achieved, as shown in **Figure 20**.*

INSTALLING THE GRILLE

At each speaker, carefully fit the grille into its recess so that it is barely in place. Starting with one corner, gently press the grille around the speaker, pushing it in a little bit each time. Be gentle – the aluminum grille can be easily bent out of shape. When properly installed, the grille will be absolutely flush in appearance with the surrounding frame.

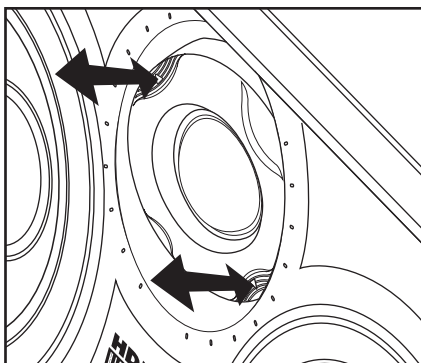

Figure 20. Pivoting the HDLCR's tweeter.

OPERATION

LISTENING AT HIGHER VOLUMES

Achieving a reasonable volume of sound in a large room requires more amplifier power than it does in a small room. It is possible to turn the volume up so high that the amplifier runs out of power. This creates “clipping” distortion, which will make treble sound very harsh and unmusical.

When you hear harsh-sounding treble from any good speaker, turn the volume down immediately! Those harsh sounds are masking much more powerful ultra-high-frequency sound spikes, which will quickly damage any fine loudspeaker. You are much less likely to damage a speaker driven by a large amplifier because it will be very loud before any clipping distortion is produced.

CLEANING

Clean the Niles HDLCR loudspeaker with a dampened soft cloth or paper towel. If the speaker is mounted high up on a wall or ceiling, use a broom to gently brush it off.

REMOVING THE GRILLE AND SPEAKER

REMOVING THE GRILLE

If you need to remove an installed grille, use a bent paper clip or the tip of a corkscrew to gently pull it away from the frame.

REMOVING THE SPEAKER

After removing the grille, use two small screwdrivers (or needle-nose pliers) to release the snaps that hold the speaker (and baffle) to the frame. Insert the screwdrivers into the holes in the snaps and exert force straight down (towards the woofer) until the snaps release, as shown in **Figure 21**.

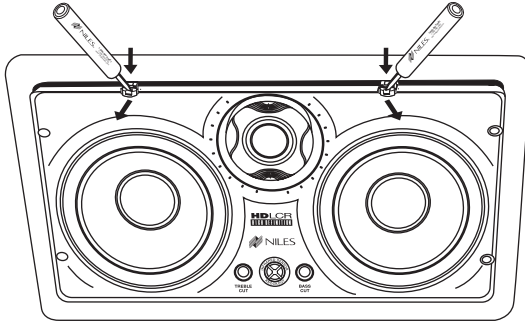

Figure 21. Removing the HDLCR speaker baffle from its frame.

Once the snaps release, the speaker can be tilted away from the frame to be removed.

NOTE: DO NOT ATTEMPT TO USE THE FRAME FOR LEVERAGE, AS THIS MAY DAMAGE THE SURFACE OF THE FRAME.

SPECIFICATIONS

Recommended Amplifier Power
10 to 150 watts per channel

Nominal Impedance
4 ohms

Frequency Response
65 Hz to 21 kHz, +/- 3 dB

Sensitivity
89 dB with 2.83 V pink noise input, measured at 1 meter on axis

Frame Dimensions
8-1/4" x 14-1/2"

Hole Cut-Out Dimensions
7-1/8" x 13-1/4"

Depth Behind Wall
3-1/2" (based on 1/2" drywall)

Wiring Requirements

We recommend using 16- to 18-gauge speaker wire for runs up to 80 feet and 14-gauge speaker wire for runs up to 200 feet. The connectors will accommodate 12- to 22-gauge wire.

LIMITED WARRANTY

NILES AUDIO CORPORATION (“NILES”) WARRANTS ITS LOUDSPEAKER PRODUCTS TO THE ORIGINAL PURCHASER TO BE FREE OF MANUFACTURING DEFECTS IN MATERIAL AND WORKMANSHIP FOR A PERIOD OF FIVE YEARS FROM DATE OF PURCHASE.

THIS WARRANTY IS SUBJECT TO THE FOLLOWING ADDITIONAL CONDITIONS AND LIMITATIONS. THE WARRANTY IS VOID AND INAPPLICABLE IF NILES DEEMS THAT THE PRODUCT HAS BEEN USED OR HANDLED OTHER THAN IN ACCORDANCE WITH THE INSTRUCTIONS PROVIDED BY THE MANUFACTURER, INCLUDING BUT NOT LIMITED TO DAMAGE CAUSED BY ACCIDENT, MISHANDLING, IMPROPER INSTALLATION, ABUSE, NEGLIGENCE, OR NORMAL WEAR AND TEAR, OR ANY DEFECT CAUSED BY REPAIR TO THE PRODUCT BY ANYONE OTHER THAN NILES OR AN AUTHORIZED NILES DEALER.

TO OBTAIN WARRANTY SERVICE, TAKE THE UNIT TO THE NEAREST AUTHORIZED NILES DEALER, WHO WILL TEST THE PRODUCT AND IF NECESSARY, FORWARD IT TO NILES FOR SERVICE. IF THERE ARE NO AUTHORIZED NILES DEALERS IN YOUR AREA, YOU MUST WRITE TO NILES AND INCLUDE YOUR NAME, ADDRESS, MODEL AND SERIAL NUMBER OF YOUR UNIT, ALONG WITH A BRIEF DESCRIPTION OF THE PROBLEM. A FACTORY RETURN AUTHORIZATION NUMBER WILL BE SENT TO YOU. DO NOT RETURN ANY UNIT WITHOUT FIRST RECEIVING WRITTEN AUTHORIZATION AND SHIPPING INSTRUCTIONS FROM NILES.

IF THE ABOVE CONDITIONS ARE MET, THE PURCHASER’S SOLE REMEDY SHALL BE TO RETURN THE PRODUCT TO NILES, IN WHICH CASE NILES WILL REPAIR OR REPLACE, AT ITS SOLE OPTION, THE DEFECTIVE PRODUCT WITHOUT CHARGE FOR PARTS OR LABOR. NILES WILL RETURN A UNIT REPAIRED OR REPLACED UNDER WARRANTY BY SHIPPING SAME BY ITS USUAL SHIPPING METHOD FROM THE FACTORY (ONLY) AT ITS EXPENSE WITHIN THE UNITED STATES OF AMERICA. THERE ARE NO OTHER WARRANTIES, INCLUDING WITHOUT LIMITATION, EITHER EXPRESS OR IMPLIED WARRANTIES OF MERCHANTABILITY OR FITNESS FOR A PARTICULAR PURPOSE, WITH RESPECT TO THE PRODUCT.

REPAIR OR REPLACEMENT AS PROVIDED UNDER THIS WARRANTY IS THE EXCLUSIVE REMEDY OF THE CONSUMER/PURCHASER. NILES SHALL NOT BE RESPONSIBLE FOR ANY INCIDENTAL OR CONSEQUENTIAL DAMAGES EXCEPT TO THE EXTENT PROVIDED (OR PROHIBITED) BY APPLICABLE LAW.

SOME STATES DO NOT ALLOW THE EXCLUSION OR LIMITATION OF INCIDENTAL OR CONSEQUENTIAL DAMAGES, SO THE ABOVE LIMITATION MAY NOT APPLY TO YOU. THIS WARRANTY GIVES YOU SPECIFIC LEGAL RIGHTS, AND YOU MAY ALSO HAVE OTHER RIGHTS WHICH VARY FROM STATE TO STATE.

**FOR THE NAME OF YOUR NEAREST AUTHORIZED NILES DEALER CONTACT:
NILES AUDIO CORPORATION, P.O. BOX 160818, MIAMI, FLORIDA 33116-0818.**

Please fill in your product information and retain for your records.

Model _____ *Serial No.* _____ *Purchase Date* _____

WARRANTY REGISTRATION CARD

Model Purchased _____

Serial Number _____

Date Purchased (month/day/year) _____

Dealer Name and Location _____

Dr. Miss Mr. Mrs. Ms.

Name _____

Address _____

City _____ State _____ Zip _____

Telephone () _____

Please take a moment to fill out our warranty registration card. The information helps us to get to know you better and develop the products you want

Age:

- Under 25
- 25-34
- 35-44
- 45-54
- 55 & over

Income:

- Under \$24,999
- \$25,000-\$34,999
- \$35,000-\$44,999
- \$45,000-\$59,999
- \$60,000-\$74,999
- \$75,000-\$99,999
- Over \$99,999

Occupation:

- Arts/Entertainment
- Business Owner
- Engineer
- Finance/Accounting
- General Office
- Management
- Professional
- Sales/Marketing
- Student
- Tradesperson

Musical tastes:

- (Please check all that apply)*
- Alternative
 - Classical
 - Country
 - Jazz
 - New Age
 - Popular
 - R&B
 - Rock
 - Other _____

How did you hear about Niles?

- Architect/Developer
- Custom Installer
- Direct Mail
- Friend/Family
- In-Store Display
- Interior Designer
- Magazine Ad
- Mail-Order Catalog
- Newspaper Ad
- Product Brochure
- Product Review
- Retail Salesperson

What magazines do you read?

1. _____
2. _____
3. _____

Who will install the product?

- Custom Installer
- Electrician
- Friend
- Myself

Which factor(s) influenced the purchase of your Niles product? (Please check all that apply)

- Ease of Use
- Price/Value
- Product Features
- Quality/Durability
- Reputation
- Style/Appearance
- Warranty

Do you . . . ?

- Own a House. If yes, how many square feet? _____

- Own a Town House/Condominium/Co-op
- Rent an Apartment
- Rent a House

- Are you interested in receiving literature on other Niles products?**
- Yes No

Are there products/capabilities that you would like to see introduced?

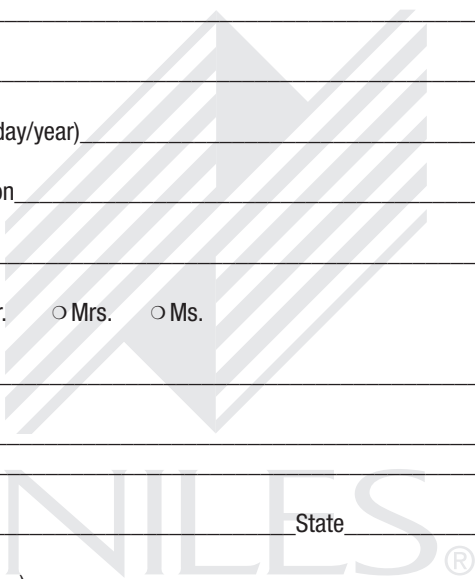

DETACH HERE AND RETURN TO: NILES AUDIO CORPORATION WARRANTY REGISTRATION DEPT. P.O. BOX 160818 MIAMI, FLORIDA 33116-0818



BLENDING HIGH FIDELITY AND ARCHITECTURE®

Niles Audio Corporation
12331 S.W. 130 Street Miami, Florida 33186
Designed and Engineered in USA
Made in China

©2005 Niles Audio Corporation. All rights reserved. Niles, the Niles logos and Blending High Fidelity and Architecture are registered trademarks of Niles Audio Corporation. All other trademarks are the property of their respective owners. Printed in China. 04/05 DS00417ACN